

YAMAHA KT100S SERIES

TECHNICAL SPECIFICATIONS



VERSION 3.0 – 01 AUG 2023

1.0 Introduction

The following are the Technical Specifications for the Yamaha KT100SE and Yamaha KT100SD engines, as approved by KNSW.

The engines must be original in all their components according to the Yamaha KT100S drawings.

Any removal, addition or polishing of material is strictly forbidden. This includes sandblasting, glass bead blasting, peening, acid etching, spark eroding and/or any other method of metal removal or displacement is not allowed.

ANY ALTERATIONS / MODIFICATIONS ARE STRICTLY PROHIBITED EXCEPT AS SPECIFICALLY AUTHORISED WITHIN THESE SPECIFICATIONS AND ANY CLASS REGULATIONS. IF THESE DO NOT SAY YOU CAN MAKE A MODIFICATION, THEN YOU CANNOT.

2.0 Engine

The maximum piston diameter and stroke length are:

Piston: 53.00mm Stroke: 46.13mm

2.1 Cylinder Machining

All machined surfaces may be re-machined as long as engine is within any other specifications within these rules.

2.2 Cylinder Ports

- a) All ports are to be in "as cast" condition except at the junction of the cast iron sleeve and aluminium jacket.
 - Grinding is permitted to remove casting irregularities at the junction ONLY. No chamfer on port edges is permitted.
 - This Rule DOES NOT allow grinding or alternations by any method to:
 - change the roof angle;
 - alter port height, width or angle;
 - change the shape or size of the passages from the cylinder base to the port;
 - match the cases to the port passages.
- b) Due to manufacturing procedures, it is possible that some engines may have slightly "broken" port edges. When this exists it is uniform on all port edges (tops, bottoms and sides) of all ports in the cylinder. The intersection of the port edges and the cylinder wall must still be within the technical measurements. As the bore size increases the amount of "break" diminishes. If the cylinder bore is 52.45mm or larger, no "broken" edges are allowed.
- c) Due to manufacturing procedures, some cylinders have some minor grinding on the transfer divider bridges and some evidence of casting irregularities removed in transfer passages, this includes the transfer area in the crankcase.

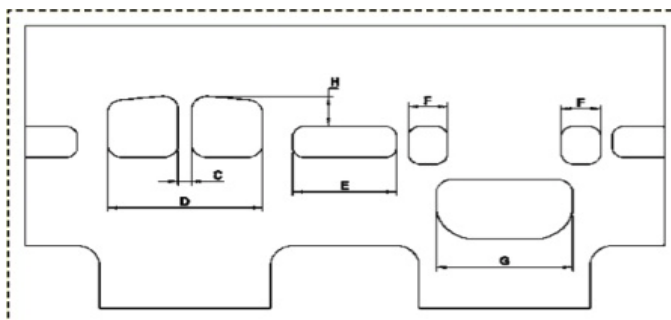

CODE	DIMENSION
C	3.4mm min
D	39.60mm max
E	26.15m max
F	13.13mm max
G	34.80mm max
H	9.50mm min

2.3 Cylinder Head

- Must be an original Yamaha casting.
- The welding and re-machining of the combustion area, gasket face is allowable. Additions/repairs must be permanent and non-adjustable. This may include an aluminium insert. Maximum diameter of any part of such repair insert is 64.00mm.
- The combustion chamber style is required to have a squish band and chamber which are visually concentric to the spark plug.
- The combustion chamber volume shall be a minimum of 11cc.
- The combustion chamber/squish area shall not protrude beyond the gasket sealing face of the

Yamaha KT100S Series – Technical Specifications

cylinder head.

- The spark plug thread may be repaired and shall retain its original position in relation to crankshaft axis. Helicoils and similar are permitted.
- Maximum distance from sealing surface of spark plug to combustion chamber sealing face shall be 32.5mm.
- Repairs to the spark plug sealing face must be by addition of weld material only and re-machining to a flat surface.
- The head gasket must be retained.

2.4 Fin Dampeners

To effectively reduce noise, it is compulsory that the Yamaha KT100S Series Engine be fitted with:

- A minimum of four rows of fin dampeners on the cylinder;
- Two rows of fin dampeners are to be fitted to the cylinder head.

Fin dampeners must make contact with all fins.

2.5 Piston

The Piston must be approved and stock appearing:

- Approved/registered pistons are Yamaha, KSI, KSI MK 11, JDP/Vertex and ARC (forged and cast) and Strike.
- The Bottom of piston should be 90 degrees to sides. It is permissible to notch the piston to allow the removal of circlip.
- The piston skirt length may be machined, providing it conforms to the current specifications as laid down in these rules.
- At no point on the inside of the skirt (of a shortened piston) can the chamfer be greater than that allowed on the outside of the skirt.

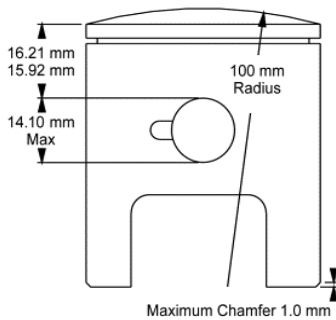

DIAGRAM IS FOR DIMENSIONAL REFERENCE ONLY.

- Note: Skirt length must be equal distance on both sides.

2.6 Connecting Rod

Can be either Yamaha or KSI and must be stock:

- Minimum/Maximum rod length, centre to centre 99.87mm – 100.13mm.
- Conrod alignment may be either top or bottom.
- Bearings and spacers are non-tech items.
- Yamaha "J" rod (50W -11651-00) is not eligible.

2.7 Crankshaft

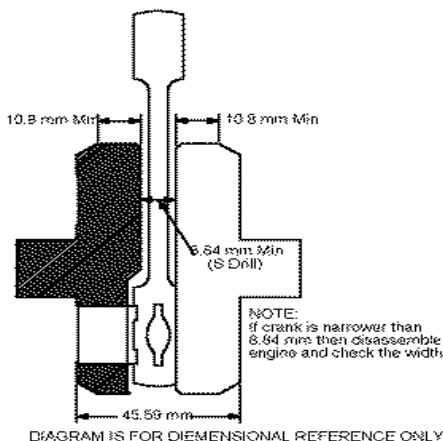

DIAGRAM IS FOR DIMENSIONAL REFERENCE ONLY

Legal crankshafts are Yamaha or KSI:

- Outside diameter measurement: 86.60mm minimum, 87.25mm maximum;
- Crank Pin to be standard hollow pin.

It is permissible to:

- Recondition the crankshaft main shaft by plating;
- Repair the drive side crankshaft end, where the threaded section has broken off by drilling and tapping the centre of the crank to accept an M6 or M8 screw.

2.8 Crankcase

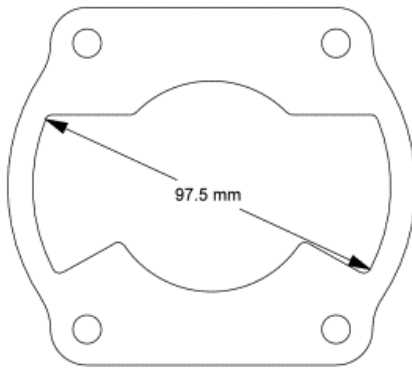

YAMAHA KT 100S

- The crankcase ports will remain as cast. The minimum chordal distance measured with a vernier caliper across the widest section of the transfer ports shall be 97.5mm minimum (Refer to diagram). All machined surfaces may be re-machined as long as engine is within any other specifications within the rules. It is permissible to repair crankcase main bearing recesses by welding or with metal inserts.
- It is permissible to use ARC electric start crankcase & crankshaft on Yamaha KT100SE & KT100SD if the clutch, starter motor, starter motor battery and electrical system is fitted.
- NOTE: Existing crankcases that are narrow may be spaced with a thicker gasket.

(DIAGRAM IS FOR DIMENSIONAL REFERENCE ONLY)

2.9 Ignition

- Ignition must be that supplied by the original engine manufacturer. Any optional unit must be approved and registered with KNSW for this class.
 - The use of the following KNSW approved TCI module is permissible on KT100SE and KT100SD engines only - YAMAHA, VICTA, ATOM, DELTA/WEI SHIEH, PRD, PRD with coil.
 - No modifications or repairs to any of the listed modules is permitted.
 - The fitting of a PRD ignition coils and a PRD ignition rotors (flywheel) is permissible (this includes the Oppama ignition system) on KT100SE and KT100SD engines only.
- Ignition timing may be adjusted by the removal of the locating key or part thereof on KT100SE and KT100SD engines only.
- All engines must rotate in a clockwise direction when viewed from the drive side.
- Ignition/rotor cover optional – compulsory for the SEC engine.
- It is permissible to repair/replace the connector on the TCI module and mating wiring.
- The external side face of the ignition rotor can be machined on outer face as long as a witness of some of the writing or lugs still remains.

3.0 Carburettor

Must be any genuine Walbro carburettor.

- It is permissible to enlarge the existing fuel / air holes, but they may not be deleted or relocated. The holes must be the same shape as originals when viewed externally.
- All air must pass through the carburettor throat.
- Adjustment of carburettor jet needles must be done by manually turning the jet needle (or its extension) only.
- Carburettor throttle cannot be actuated by electro mechanical means.
- It is permissible to fit a mechanical stop to limit the range of carburetor jet needle movement, however no modifications to the carburettor are permitted to mount such a stop.

3.1 Pressurised Fuel Systems

- Fuel pump or pressurised fuel systems are forbidden.
- Squeeze type pump between fuel tank and carburettor is permitted.

4.0 External Modifications

External modifications, which do not in any way affect a performance gain, are legal.

4.1 Internal Parts

All internal parts must be finished as per Yamaha Factory specifications.

4.2 Internal Additions

- No additional material may be added except in the case of engine repairs and shall only restore engine or components to original specifications. The cylinder may NOT be repaired in any of the port or passage as cast areas.
- The use of thermal barrier coatings / ceramic coatings on or in the engine / engine components and on or in exhaust components is prohibited.
- The use of anti friction coatings on or in the engine / engine components is prohibited.

4.3 Legal Additions

Legal additions shall be limited to the following: Chain guard, motor mount, direct drive gear, extension of carburettor jet needles, carburettor return springs, third bearing and adapter (for ARC clutch only), temperature gauge and tachometer.

4.4 Non-tech Items

Non-tech items are gaskets, seals, big end roller/cage, little end spacers, rings, washers, cages, fasteners, fulcrum spring (carburettor meter levering spring), spark plug and spark plug lead and cap, gudgeon pins, main bearings, coolant sealing "O" rings, engine sprocket and key.

- Non-tech items are to be of the same type and style as the original. No alteration from the original manufacturer's specifications is permitted to fit a non-tech item.
- Head gasket/s must be retained.
- Cylinder base baskets are dimensionally free.
- Carburettor base and phenolic spacer gaskets are dimensionally free.
- Only crankcase half gasket may be formed from liquid gasket compounds.
- Cylinder base adjusting shims/spacers may be of any material and must be of uniform thickness.
- Spark plugs must have a maximum engagement length of 20mm without the washer.
- A direct drive sprocket (complete) cannot weigh more than 100 grams.
- A direct drive sprocket retaining nut cannot be made from a hex material greater than 19mm AF.
- Pull start and electric start systems are non-tech.

5.0 Exhaust Header Pipe

The Exhaust Header Pipe is not restricted to the original Manufacturer, but must conform to the type (style) and of the original header pipe:

- Inside diameter must be parallel.
- Minimum Length permitted 120mm, as per diagram.
- Minimum inside diameter of 34mm and maximum inside diameter of 36mm.
- It is permissible to stiffen the exhaust flange to the extent shown in the drawing.
- The maximum length from the engine side face of the flange to the end of any stiffening is 20mm.
- Any stiffening must not interfere with the fitting of exhaust seals.
- Modifications to fit a maximum of one (1) exhaust probe are permissible.
- Exhaust header studs must remain in their original position.

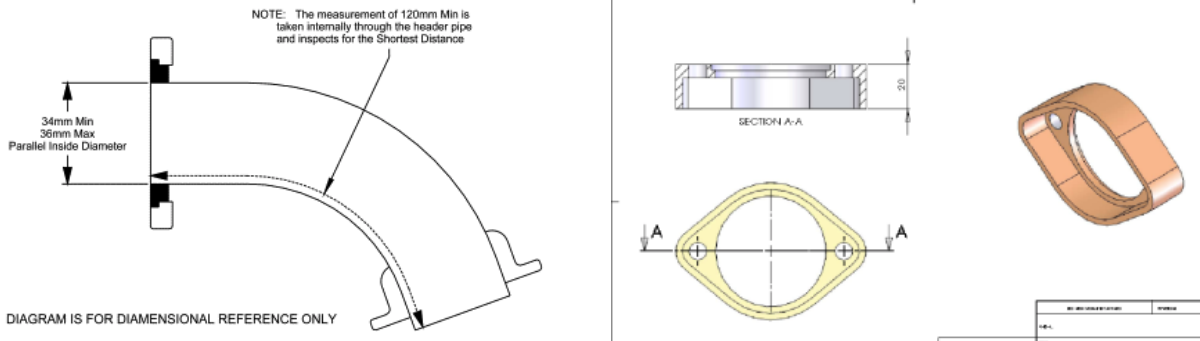

5.1 Exhaust System

- Must be such as to carry the exhaust gases away from and to the rear of the driver.
- Exhaust gases must all pass through the exhaust header pipe and the muffler (and silencer if used) at all times.
- Mufflers must conform to the Technical Regulations in regards to maximum noise levels.
- The open end must point in such a way so that it does not present a hazard to other drivers.
- Muffler must be securely fastened with springs to a mounting bracket cradle and to the header pipe of the engine. A secondary fastening system, comprising a multi-strand wire (as used in throttle cables) to be secured through a fixing lug or a similar attachment (e.g. hose clamp) on the muffler and must be attached to the kart frame.
- It is permissible to use, externally, heat proof wrapping between the springs and exhaust cradle and the springs and flex.

5.2 Exhaust Muffler

Any commercially available muffler ~~conforming to the dimensions below~~ may be used.

- However, the muffler main body section **must be parallel** and measure the same outside circumference (minimum 278mm) for its entire length.
- ~~• This does not include any heatshield, brackets or attachments e.g.: safety wires or safety spring retainers.~~
- ~~• No device capable of being moved whilst racing is allowed, either in or on the muffler.~~
- It is permissible to weld fixing lugs to the external surface.
- With the exception of repair to fixing lugs, any attempt to repair damage, or alter the muffler by cutting, welding or fabrication, will automatically remove eligibility of the muffler.
- ~~• Unless specified as a maximum measurement, all dimensions are subject to Technical Regulations – General Tolerances.~~
- ~~• Any measurement related to welds, will be taken to the centre line of the weld.~~
- The exhaust header pipe and muffler can be joined by a pipe or flexible tube with a constant wall thickness and must be a minimum 36.0mm inside diameter. ~~and have ends perpendicular to the tube centreline. maximum 46.5mm outside diameter these being an absolute size all TOLERANCES included.~~
- ~~• Exhaust spacers are allowed and must be of material equal to the permitted size of the joining exhaust flex or pipe, be of parallel bore with perpendicular ends.~~

6.0 Clutch

Clutches are mandatory for all Sprint Classes.

The only permissible clutches to be used with the Yamaha KT100S series engine are the following:

- Freeline SL AKA # 44 (short shaft) only
- Strike SSS AKA # 45 (short shaft) only
- Ital Red AKA # 55 (short shaft) only
- Tomar TD22 AKA # 56 (long shaft) only
- ARC (ARC electric start bottom end) only
- Strike SSS evolution AKA # 47 (Yamaha SEC engine) only
- KT100SEC 7yps AKA # 57 (Yamaha SEC engine) only
- Drive belt pulley AKA # 52 (SSS clutch) only
- Ital Red "S" Taperlock AKA # 55A (Short shaft) only
- Zedtec ZD1 Long shaft and short shaft