

TEKA

THE ENDURANCE KARTING ASSOCIATION

20 YEARS

2020 Animal Rule Set



Effective January 1, 2020

The Animal engine platform was designed and engineered exclusively for racing. Each engine is hand-built in Milwaukee, Wisconsin using dedicated tooling and dies to provide a level of consistency unmatched in the industry today.

All Briggs & Stratton (B&S) racing engines are manufactured solely for sanctioned racing only. B&S does not recommend the products referenced herein to be used for an application outside of sanctioned racing as serious injury or death could result.

This rule package has been prepared by Briggs & Stratton Racing then adapted by TEKA and is intended to establish the sole basis for technical control of the Animal engine in TEKA competition.

**UNLESS THESE RULES STATE THAT YOU
CAN DO IT, YOU CANNOT DO IT.**

**EACH RACER IS SOLELY RESPONSIBLE TO MAINTAIN AND
CHECK ENGINE LEGALITY PER THIS PUBLISHED RULE SET**

**This rule package covers all engine related technical specifications.
For all other regulations beyond the engine please refer or contact
Karting New South Wales**

CONTENTS

1.	These Regulations Are the Only Regulations.....	3
1.5.	The 3 Core Rule Set Technical Inspection Principals:	3
2.	Briggs & Stratton Animal Product Availability	3
3.	General Rules	3-4
4.	Things That Are NOT Permitted.....	4
5.	Engine Sealing	4-5
6.	Technical Inspection Tools	5
7.	Engine Ignition Switch.....	5
8.	Engine Air Filter	5-6
9.	Engine Fuel Recommendations	6
10.	Engine Oil	6
11.	Oil Breather.....	6
12.	Oil Catch Container.....	7
13.	Carburetor Overflow	7
14.	Fuel System	7
15.	Cooling Shrouds, Covers and Blower Housings	7-8
16.	Damaged Thread Repair	8
17.	Carburetor & Intake Manifold	8-10
18.	Cylinder Head	11
19.	Head Gasket.....	11-12
20.	Ports	12
21.	Valves	12-13
22.	Valve Springs	13
23.	Rocker Arms, Rocker Ball and Rocker Arm Studs	13
24.	Push Rods	13-14
25.	Engine Block.....	14
26.	Valve Lift	14-15
27.	Camshaft Profile Limits.....	15
28.	Flywheel	15
29.	Ignition System and Ignition Timing	15-16
30.	Crankcase	16
31.	Clutch	16
32.	Starter	16
33.	Exhaust system.....	17
34.	Non-Tech Items	17
35.	Technical Inspection Tools	17
36.	IMPORTANT ONLINE SUPPORT RESOURCES.....	17
37.	TOOL REFERENCE.....	18
38.	PART NUMBER DIAGRAMS	19-24

1. These Regulations Are the Only Regulations

- a. Only the TEKA Committee can make changes to the technical specifications herein.
- b. B&S dealers and their agents are not authorized to alter, verbally or otherwise, any technical specifications or competition rule herein.
- c. Should any B&S literature, catalogues, manuals, videos, etc. be different than these regulations, these regulations take precedence.
- d. Changes, corrections, addendums, etc. will be submitted and posted at www.teka.com.au for republication and will become effective on a date specified.

1.5. The 3 Core Rule Set Technical Inspection Principals:

- a. Unless these rules state that you can do it, you cannot do it.
- b. Spirit and Intent (Syd White rule): Covered, stated, restated, or unstated any change or action with the sole intent to wrongfully create a performance advantage is grounds for disqualification.
- c. All parts are subject to comparison with a known stock part. This includes specified and mandated aftermarket parts. Example: TEKA exhaust and silencer.

2. Briggs & Stratton Animal Product Availability

- a. The Animal engine products and service parts are available only through the authorized Briggs & Stratton Racing dealers.
- b. A list of authorized dealers can be found at www.teka.com.au

3. General Rules

- a. The terms stock, original equipment, OEM, unaltered, etc., refer to Original Equipment supplied by Briggs & Stratton.
- b. Only the original equipment Briggs & Stratton 206 #124332-8201-01 (with animal ignition fitted) or Briggs & Stratton Animal #124332-8003-01 engines are allowed in the classes herein.
- c. All parts must be unaltered Briggs & Stratton Animal/206 parts specifically made for these engines by Briggs & Stratton. No aftermarket parts to be used unless specified in these regulations.
- d. All parts are subject to comparison with a known stock part. This includes specified and mandated aftermarket parts. Example: TEKA exhaust

e. A tech official may use additional means of measuring components to compare against a known stock part.

- f. All Briggs & Stratton Animal/206 engines must have all TEKA Seals/logbooks in place. Engine blocks (Cylinder Assembly) without TEKA Seals/logbooks are illegal in competition.
- g. Standard organizational protest procedures can allow for short block

inspection (seal removal) if a *new*, replacement short block, p/n 555715 is offered in replacement. Competitor short block to be forfeited to the series or club as terms of this procedure.

- h. It is permitted to get your motor "rebuilt" replacing things such as rod, piston, rings, valves and seals with original Briggs and Stratton Animal components (part numbers located in this document) so long as no machining/honing/material removal is undertaken and your motor must be presented to a TEKA approved engine sealer to be measured, sealed and documented in its individual log book to make it legal for competition. It is permitted for the approved engine sealer (and only an approved engine sealer) to give your block a light hone to assist with bedding in of new rings

4. Things That Are NOT Permitted

- a. Tampering of the B&S factory or TEKA installed engine seals.
- b. Addition or subtraction of material in any form or matter.
 - a. Exception – Valve maintenance (slight lapping to improve valve to seat seal). Valve seats must remain with the factory specification of 30 and 45 degree angles only. Valve seats of additional angles and/or angles not comparable to the factory stock of 45 degrees are not permitted. Grinding of valve stem or excessive material removal prohibited. Valve maintenance can only be performed by an authorised engine sealer
 - b. If replacing valve guides the bore of the replacement Valve Guide Bushing #555645 is undersize as supplied, therefore the guide bore requires reaming when fitted into the cylinder head. Following reaming the valve seat/s in the cylinder head will need to be faced to ensure concentricity of valve face to valve seat. This can only be performed by an authorised engine sealer.
- c. "Blueprinting" unless stated herein.
- d. Modification to or the machining of any parts in order to bring them to stated minimum/maximum specification, (or for ANY reason).
- e. Machining or alteration of any kind to the engine or replacement parts unless specifically stated herein.
- f. Deburring, machining, grinding, polishing, sanding, media blasting, etc.
- g. Sandblasting or glass-beading any interior engine surfaces.
- h. No device may be used that will impede, or appear to impede, airflow to the engine cooling system.
- i. Honing your block by anyone other than an approved TEKA engine sealer.

5. Engine Sealing

- a. All engines must have the official TEKA fitted seals in place as well as the original B&S seals (if applicable) and be delivered with its own TEKA log book and serial number. The log book must be readily available at all times during a race meeting. Not having a valid logbook present at a race meeting is grounds for disqualification.
- b. Tampering with or breaking the seals is not permitted. Should the seals be tampered with or be broken, the engine will no longer be eligible for competition. "Tampering" includes interfering with the fasteners and/or damage to or breakage of the wire/seal

itself. Take proper care of your seals to ensure their integrity.

- c. Only authorised TEKA engine sealers are allowed to seal engines after carefully inspecting the engine according to the Technical Specifications for the Briggs and Stratton Animal engine. Special TEKA engine seals must be used. A record of any and all repairs is to be noted in the engine log book, dated, signed and stamped by a TEKA engine sealer.
- d. At race scrutineering, the team representative, is to present the engines with undamaged seals and its corresponding log books showing the correct matching serial numbers, seal numbers, stamp and signature of the authorised TEKA engine sealer.
- e. In the case of a protest or post-race scrutineering, scrutineers can open and check the engines and their log books. These actions will be in accordance with these rules.
- f. After checking the engines step by step to ensure it is in accordance with the technical specifications hereunder, the scrutineer in conjunction with the TEKA engine sealer will reseal the engine.
- g. Seal locations:

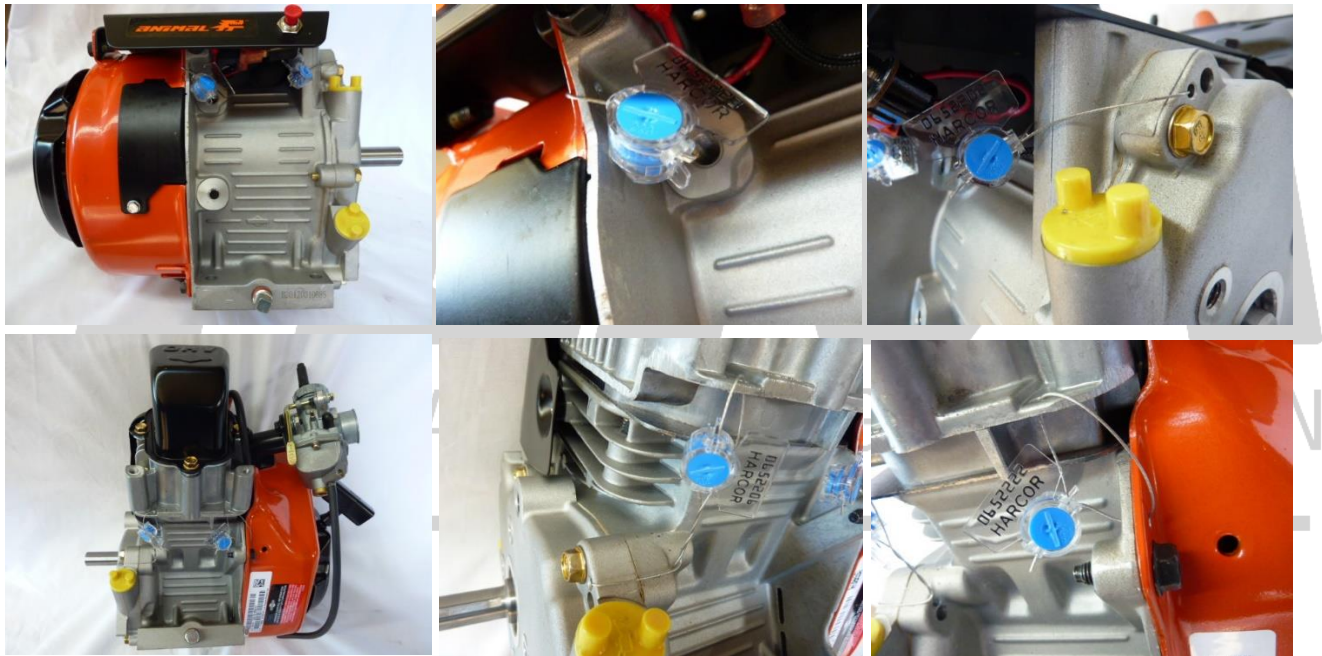

6. Technical Inspection Tools

Briggs & Stratton have made available a number of tools for the convenience of technical checking of components when necessary. They are indicated throughout the rule thusly: **Tech Tool #**. See Section 38 for tool description. The tools are available from:

Sox Racing • 2223 Platt Springs Rd. • West Columbia, SC 29169 • (803) 791-7050

7. Engine Ignition Switch

Remote engine ignition kill switches are permitted however the standard B & S ignition kill switch and wiring must be retained unaltered and in stock location and must function independently of any remote engine kill switch.

8. Engine Air Filter

- a. There are 2 air filters allowed for competition: Briggs & Stratton Green Air Filter Part #555729 OR Replacement foam Air filter UP4112A purchased from UNIFILTER. No modification to either filter element is permitted.
- b. A protective shield may be attached for wet-weather competition.
- c. It is not permitted for the protective shield to create any ram-air effect.
- d. A fabric prefilter is allowed as long as it does not create a ram-air effect. Foam or any other prefilter material is NOT legal for use.
- e. A racer MUST start each race with the air filter properly attached but will NOT be penalized if the air filter falls off during the race. If air filter falls off during a race, it is STILL subject to tech.
- f. It is permitted to securely fit an intermediate one or two piece extension tube made of fire resistant material with an internal diameter no greater than the air intake bell with a maximum bend angle of 90 degrees between the filter and carbie so long as the filter is attached to the carbie in the most direct way possible. This intermediate pieces are not allowed to create a ram-air effect.



9. Engine Fuel Recommendations

Premium Gasoline no greater than 98 octane sold at normal roadside fuel stations open to the public. The addition of fuel additives in any manner is not permitted. Fuel dispensing location may be specified in Event Supplementary Regulations. Specific gravity and hydrometer testing are acceptable tests when used in accordance to sanctioning body guidelines.

10. Engine Oil

- a. Type/weight of oil used is open. High-quality synthetic oil within a 10W-20 range recommended. No oil additives are permitted.
- b. Briggs & Stratton **only** recommends the use of Briggs & Stratton 4T Synthetic Racing Oil. 4T was engineered exclusively for the rigors of high revving, air-cooled racing engines (available through both Briggs Racing and Amsoil dealers). The use of 'karting' or 'automotive' oils is **not** recommended as many are hydroscopic in nature (attract water), offer limited protection over time, and/or were engineered for pressure, not splash lube systems. The use of these oils can induce engine failure and/or accelerate wear.
- c. Briggs recommend the use of "Running In" oil for new and rebuilt engines during the engine break in period.
- d. Engine oil testing/verification procedure is per standard sanctioning body guidelines.
- e. No engine oil additives are allowed.

11. Oil Breather

Oil breather must vent to a catch container.

12. Oil Catch Container

An oil overflow catch system is mandatory. Overflow tube must run from the crankcase breather to a catch container. The catch-container must be vented to atmosphere.

13. Carburetor Overflow

Carburetor overflow must be vented to a catch container. The catch-container must be vented to atmosphere.

14. Fuel System

- a. Only fuel pump, B&S part number 808656 or 597338, is legal for competition. This fuel pump can be identified by the Briggs & Stratton diamond logo on the pump face. All other pumps are prohibited.
- b. Relocation of the fuel pump is legal as long as it is spaced to less than 3/4 inch off of the control plate, B&S #555699, in a similar location that is both safe and secure. Measurement is from the base of the control plate to the bottom of the fuel pump. Vertical mounting or mounting the fuel pump upside down is NOT allowed.
- c. Pulse pumps port fittings may be fitted to one of the following; The inlet manifold Cylinder head inlet tract, or Utilizing the oil cap. If via the inlet manifold or cylinder head, the fitting used must be a commercial off the shelf product with no modifications and must be installed flush to 0.5mm maximum protrusion into the inlet manifold tract or cylinder head tract. If the inlet manifold tract or cylinder head inlet port is modified in any other way the engine will not pass scrutineering.
- d. The use of fuel return lines is permitted
- e. The use of silicone sealant on the brass vent IS permitted and recommended.
- f. A fuel filter is not required but highly recommended to insure that dirt and contamination within your fuel system does not impact your carburetors performance. The fuel filter itself is not a tech item but only one fuel filter per motor is legal for use and it can only be located between the fuel tank and fuel pump inlet (not between the pump outlet and carburetor). The maximum Fuel capacity of all filters (in total) is not to exceed 60ml.
- g. All Karts must only be fitted with one (1) Fuel tank maximum capacity nine (9) litres only.
- h. A maximum of one (1) hand operated in-line Fuel Primer Bulb is permitted per engine part number Yamaha 6y1-24360-52, 6mm primer bulb, or equivalents are permitted.
- i. All Fuel line must be a maximum ID of 6mm or 1/4 inch and attached from the fuel tank to the motor in the most direct way possible.



15. Cooling Shrouds, Covers and Blower Housings

- a. All pieces of the engine cooling shroud/blower housing and control panel must be stock B&S and properly installed. Rewind housing and cooling shroud (air guard) must remain stock as painted from the factory.
- b. Any bolt, with the exception of the head bolt, that is used to secure sheet

metal shrouds and covers may be replaced with larger diameter bolts.

- c. No taping, covering, or restricting of air to the rewind shroud is permitted.

16. Damaged Thread Repair

- a. It is permitted to use Heli-coil, Time-sert or a similar thread repair insert for shrouds, valve cover, oil drain, oil fill holes, blower housing, and exhaust pipe attachment studs on the head and lower brackets.

17. Carburetor & Intake Manifold

- a. The B&S stock carburetor part #555658 is the only carburetor permitted. 'Walbro', 'Briggs' diamond logo and/or #590890 etched in the body are additional visual indicators. No alterations allowed unless stated below. All parts will be compared to a stock known B&S part for eligibility. This includes the nozzle, emulsion tube, jets, float, float needle and all other carburetor parts. It will be allowed however to adjust the float height by means of bending the small tab on the float arm.
- b. A slight chamfer around the choke bore ID (air horn) may be present. 1.149"(29.2mm) no go **Tech Tool A7**.
- c. Main Jet is size open (recommended range 88-95)
- d. Idle jet must remain stock, as shipped from the factory.
- e. Slide must remain B&S stock unaltered. Slide cutaway to be measured on flat surface. .075 (1.9mm) no go **Tech Tool A10**. ALL intake manifold fasteners to remain factory stock. The use of studs, etc. are illegal.
- f. All individual carburetor components must be tight, as shipped from the factory.
- g. B&S stock unaltered aluminum needle is required part number 555602 marked #BGB. Needle to be inspected using **Tech Tool A4**. Needle, when placed in tool A4, should not protrude through the other side. If needle protrudes through the block it is out of specification.
- h. Throttle cable cap on the top of the carburetor must be properly installed and secured in the fully tight position.
- i. Metal choke cover must remain in place but may be secured with silicone or epoxy sealer. Additional pin punching is allowed to tighten choke cover. A spring/ cable tie/ O-ring is allowed to hold the choke lever in the closed position.
- j. Air must only enter the engine from the natural air filter horn of the carburetor. Air entering through any other method is illegal. An approved spray test method can be used for tech validation.
- k. Welding and bracing of the inlet manifold is permitted provided that the overall dimensions and location must be as per a stock manifold.



Idle Pilot Jet -
 Stock, Unaltered
 .0130" No-Go (Use
 .130" Class Z No-Go)

Emulsion Tube - Stock, altered
Small Holes - .018 Go (Use .018" Class Z Go)
 .021" No-Go (Use .0215" Class Z No-Go)
Big Holes - .026" Go (use .026" Class Z Go),
 .029" No-Go (Use .029" Class Z No-Go)



Main Jet -
 Open

Main Nozzle -
 Stock, Unaltered
 .101" Go (.101" Class Z Go)
 .0104" No-Go
 (Use .0104" Class Z No-Go)

Venturi Horizontal Measurement - (Tool A20)
 (narrowest part) = .602" No-go
 can't pass into the slide area.

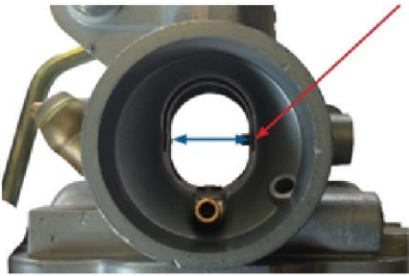

Venturi Horizontal Measurement-
 (Tool A8)
 (widest part) =
 .615" No-go
 can't pass into
 the slide area.

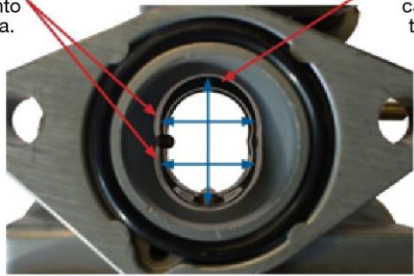

Venturi Vertical Measurement-
 (Tool A8)
 .792" No-go
 can't pass into
 the slide area.

Venturi Idle Fuel Hole -
 .039" No-Go (Use .039" Class Z No-go)
 Use pin gauge and access from the slide opening.



Air Pick Off Hole -
 .057" Go (Use .057" Class Z Go),
 .061" No-Go (Use .061" Class Z No-Go)

Venturi Idle Air Hole -
 .119" No Go
 (Use .1195" Class Z No-Go)

NOTE: Slide openings should be measured only with the Briggs & Stratton slide tool listed on the tool reference

20 YEARS

TEKA 2020 Animal Engine Technical Specification

Technical Item	Description	Tech Tool
a. Needle Jet C-Clip	Needle Jet C-clip must be properly installed but may be installed at any of the 5 factory settings on the needle jet.	
b. Throttle Cable Cap	Throttle cable cap on the top of the carburetor must be used and properly installed in tight position.	
c. Choke	Choke: OEM unaltered, but lever may be fastened open with a spring, rubber band, wire, etc.	
d. Idle Pilot Jet	Idle Pilot Jet – Stock, Unaltered .0130" (0.32mm)No-Go (Use .0130" (0.32mm) Class Z No-Go)	
e. Idle Circuit Air Hole	No drilling, reaming, elongating of the hole allowed. .119" (3mm) maximum diameter. A small chamfer at the outer edge, as compared to a stock part, can be present. The measurement of that chamfer is subject to sanctioning body guidelines.	.1195" Pin gauge
f. Main Jet	Main jet – Open	
g. Emulsion Tube	Main nozzle – OEM stock unaltered hole size = .101(2.5mm)- .104" (2.6mm) Small holes – .018" (0.45mm) Go (Use .018"(0.45mm) Class Z GO) - .021"(0.5mm) No-Go (Use .0215" (0.5mm) Class Z No-Go) Big Holes - .026" (0.65mm) Go (use .026" (0.65mm) Class Z Go) - .029"(0.7mm) No-Go (Use .029" (0.7mm) Class Z No-Go)	
h. Venturi Measurement	Venturi Measurement: Vertical: .792 max inches (20.1mm).	A8
	Horizontal: .615 max inches (16.5mm) at widest part	A8
	Horizontal: .602 max inches (15.3mm) at narrowest part.	A20
i. Air Pick Off Hole	Air pick off hole - .057 (1.4mm) go .061 (1.5mm)no go	A9
j. Throttle Bore	Throttle bore – Must be as cast and bore max diameter = .874 inches (22.2mm)	A7
k. Venturi Idle Fuel Hole	Venturi idle fuel hole =.039"(0.9mm) No-Go (Use .039" (0.9mm) Class Z No- go)	
l. Air Filter	Air filter: part # 555729 and replacement foam UNIFILTER air filter is allowed. 90 degree Filter adapters are allowed, the filter must be attached to the carbie in the most direct way possible	
m. Carburetor Overflow	Carburetor overflow: Must be vented to a catch container.	
n. O-Ring	O-Ring part number B&S part # 555601 is required and must be unaltered.	A12
o. Intake Manifold	Intake manifold – max length = 1.740 inches (44.2mm) min to 1.760 inches (44.7mm) max	
	Intake manifold – bore diameter = .885 inches (22.45) min to .905 inches (23mm) max	A11
p. Choke Bore/Air Horn	1.149 (29.1mm) no-go	A7
q. Carb Slide Cutaway	.075 (1.9mm) no-go	A10
r. Widest part of Combustion Chamber	2.640 (67.06mm)	A30

18. Cylinder Head

- a. The ONLY head casting for the B&S Animal/206 herein is the '**RT-1**', cast into the head just off the head gasket surface (towards the rear of the engine, PTO side). The overall head minimum thickness is 2.431" (61.74)mm.
- b. Cylinder head must be "as cast". Factory machining marks left on the head gasket surface is a tech item.
- c. Hard carbon may be scraped from head before measuring.
- d. Depth of shallow area of combustion chamber must be .031 inch (0.79mm) minimum. This measurement to be taken with a depth gage on both the combustion side and spark plug side of cylinder head.
- e. Depth of the combustion chamber is .342" inches (8.69mm) minimum.
- f. Depth of top of valve seat = 9.15mm maximum to 8.5mm minimum.
- g. Head thickness is measured from head gasket surface to head plate gasket surface = 61.5mm (measured in 4 places through valve guides and push rod holes).
- h. Width of combustion chamber at the widest part across the valve seat area = 67.05mm no-go at a depth of 5.1mm in the combustion chamber. Cylinder head combustion chamber volume is 28.5cc.
- i. Inspect retainers for alterations that would increase valve spring pressure - .055" (1.4mm) to .075" (1.9mm) maximum flange thickness. Both intake and exhaust must have OE stock B&S valve keepers.
- j. Unaltered B&S part #555552 (exhaust) and #555551 (intake) can be checked for appearance, weight, and dimensions. No machining, polishing, easing, or alterations of any kind allowed. Valve surface must remain as factory, with one single 45 degree face. No other additional angles allowed on any part of the valve. **Tech Tool A22.**
- k. Valve Guides: Replacement of valve guides with B&S part #555645 only is allowed. Maximum depth from the head gasket surface to the intake valve guide is 1.255" (3188mm).
- l. Briggs & Stratton heat disperser, part # 555690 can be installed in the exhaust bolt boss per factory instructions.

19. Head Gasket

- a. Unaltered B&S part #555723 is allowed. Measurement must be performed using a micrometer. Readings are taken from inside the cylinder hole of the gasket closest to the combustion chamber (see diagram). Four measurements are to be taken in the four defined quadrants with 3 meeting the minimum thickness of .047" (1.194mm).
- b. Unaltered B&S "Fire ring" gasket part #555698 is also allowed. Measurement must be performed



using a micrometer. Readings are taken from inside the cylinder hole of the gasket closest to the combustion chamber (see diagram). Four measurements are to be taken in the four defined quadrants with 3 meeting the minimum thickness of .042" (1.067mm).

20. Ports

- a. No de-burring, machining, honing, grinding, polishing, sanding, media blasting, etc.
- b. The transition from intake bowl to port must have factory defined machining burr at this junction.
 - *No addition or subtraction of material in any form or matter.
 - *No alterations of any kind may be made to the intake or exhaust ports.
- c. Intake Port: Maximum diameter measurement = .918 inches (23.32mm) max. **Tech Tool A6.**
- d. Exhaust Port AS CAST. Exhaust Outlet -.980 (24.89mm) – **Tech Tool A6.**
- e. Valve Seats. Intake and exhaust: Must remain factory specification with 45 degree angle only. Valve seats of additional angles and/or angles not comparable to the factory stock are not permitted.
- f. Valve maintenance permitted (slight lapping to improve valve to seat seal). Valve seats must remain with the factory specification 45 degree angles only. Valve seats of additional angles and/or excessive material removed when compared to the factory stock is prohibited. Valve maintenance can only be performed by an authorised engine sealer.
- g. Intake valve seat diameter inside = maximum .972 inches (24.7mm). **Tech Tool A2.**
- h. Intake port pocket bowl (area just below valve seat) = .952 (24.2mm) no go **Tech Tool A2**
- i. Exhaust valve seat diameter inside = maximum .850 inches (21.6mm). **Tech Tool A1.**

21. Valves

- a. Intake valve p/n 555551

Minimum Weight of Valve	27.8 grams
Diameter of valve stem	.246" (6.25mm) to .247" (6.274mm)
Diameter of valve head	1.055" (26.8mm) to 1.065" (27.05mm) Tech Tool A17
Diameter of valve seat	.972" (24.69mm) ID maximum
Valve length	Minimum 3.3655" (85.484mm)
Height from angle of valve face to top of the valve	.057" (14.48mm) minimum

	Tech Tool A26
--	----------------------

b. Exhaust valve p/n 555552

Minimum Weight of Valve	27.2 grams
Diameter of valve stem	.246" (6.25mm) to .247" (6.274mm)
Diameter of valve head	.935" (23.75mm) to .945" (24mm) Tech Tool A18
Diameter of valve seat	.850" (21.59mm) ID maximum
Valve length	Minimum 3.3655" (85.484mm)
Height from angle of valve face to top of the valve	.060" (1.524mm) minimum Tech Tool A27

22. Valve Springs

- Valve Springs are single coil stock, unaltered B&S part #26826. Must be identical in appearance to factory part and have 4.00 to 4.75 coils in stack.
- Spring Wire Diameter: .103" (2.62mm) to .107" (2.72mm)
- Valve spring length: .940" (23.88mm) max **Tech Tool A15**
Inside diameter: .615" (15.621mm) Go (Use .615 (15.621mm) Class Z Go) - .635" (16.129mm) No-Go (Use .635" (16.129mm) Class Z No-Go)

23. Rocker Arms, Rocker Ball and Rocker Arm Studs

- Rocker arm must be stock B&S part #555711 (US) or #797443 (METRIC) and may not be altered in any way.
- Rocker studs must be stock, unaltered B&S part #694544 US (1/4-28 thread) or #797441 Metric (M8x1.00 thread) and in stock location.
Rocker arm #555711 (US) must be used with rocker stud #694544 (US).
Rocker arm #797443 (Metric) must be used with rocker stud #797441 (Metric).
- Rocker Ball must B&S stock. Diameter .590" (14.99mm) min. to .610" (15.49mm) maximum. **Tech Tool A16.**
- Rocker arm mounting positions may not be altered in any manner. No heli-coiling of mounting holes. No bending of studs.
- Rocker arm stud plate must be bolted to the head with one, OEM stock B&S gasket only – no alterations. Maximum thickness of gasket is .060 inches. Rocker plate to head fastener holes must remain stock, .289" (7.34mm) max.
- Rocker arm – overall length 2.820" (71.63mm) minimum. Can be checked with a pair of dial calipers.

24. Push Rods

- a. Push rods must be unaltered stock B&S part #555531/#693517
- b. Push rod diameter .183" (4.65mm) minimum to .190" (4.83mm)
- c. maximum. Push rod length 5.638" (143.2mm) minimum to 5.658" (143.6mm) maximum. **Tech Tool A5.**
- d. Push rod diameter to be checked 3 points along the length and must pass two planes on each 360 degrees of rotation.

25. Engine Block

- a. Engine block must be unaltered "as cast" B&S factory machined condition. There must be no addition or subtractions of metal or any substance to the inside or outside of the cylinder block.
- b. All TEKA seals must be present with both the fastener and seal in "as shipped" from the factory location and condition. Any defined tampering with the fasteners or damage to the wire/seal itself (example: delaminated hologram) are grounds for disqualification.

Take proper care of your seals to ensure their integrity. It is recommended that you wrap your seals (using a plastic bag, etc.) to prevent exposure to harsh solvents such as carb cleaner, etc...

- c. Deck gasket surface finish is a tech item. Piston pop up can be .0035" (0.09mm) maximum. Piston pop-up to be checked with flat bar in center of piston parallel to piston pin and then again checked 90 degrees to piston pin. Push piston down to take up rod play. **Tech Tool A25.**
Angle milling or peak decking is not allowed.
- d. Carbon build-up can be removed before pop-up is measured as long as material is not removed from the piston. Exception – Competitors can deburr the manufacturing part number/marks IF needed as long as:
 - Removal does not extend beyond the defined script area.
 - De-burring does not extend below the original piston surface area.
 - The original part numbers and script are still clearly visible.
- e. Cylinder bore will not be bored oversize
- f. Cylinder bore will not be re-sleeved.
- g. Cylinder bore position is not be moved or angled in any manner.
- h. Cylinder bore dimension: - Briggs & Stratton stock bore is 2.690" (68.33mm). Allowance for wear is permitted up to 2.693"(68.40mm) maximum for entire length, top to bottom.
- i. Maximum stroke is 2.204" (55.98mm). Push piston down to take up rod play. Check stroke on BDC to TDC. **Tech Tool A21.**

26. Valve Lift

- a. Maximum valve lift is checked from the top of the valve spring retainer. Valves must be adjusted to zero clearance.
- b. Valve Lift: Camshaft check is taken at the valve spring retainers. With the lash set at zero, the movement of the valve spring retainers may not exceed the

following: Intake and exhaust: .255" (6.48mm) maximum.

27. Camshaft Profile Limits (measured at the push rod)

Push gently down on dial indicator stem to ensure that there is no lash when push rods are going down.

NOTE: Due to the extended life of the engine, a single point on each lobe can be off by a maximum of 2 degrees without issue, the exception being on the .006" (0.15mm) check, both intake and exhaust.

Intake lift	
0.006	59 TO 51 BTDC
0.020	16 TO 12 BTDC
0.050	.5 TO 4.5 ATDC
0.100	17 TO 21 ATDC
0.150	33.5 TO 37.5
0.175	43 TO 47 ATDC
0.200	54 TO 58 ATDC
0.225	68 TO 72 ATDC
MAX LIFT	0.257
MIN LIFT	0.252

Exhaust lift	
0.006	101 TO 93 BBDC
0.020	59 TO 55 BBDC
0.050	43 TO 39 BBDC
0.100	26 TO 22 BBDC
0.150	9 TO 5 BBDC
0.175	1 TO 5 ABDC
0.200	11.5 TO 15.5
0.225	25 TO 29 ABDC
MAX LIFT	0.259
MIN LIFT	0.252

Intake lift	
0.225	38 to 34 BBDC
0.200	24.5 TO 20.5
0.175	14 TO 10 BBDC
0.150	4.5 TO .5 BBDC
0.100	12 TO 16 ABDC
0.050	29 TO 33 ABDC
0.020	45.5 TO 49.5
0.006	83 TO 91 ABDC

Exhaust lift	
0.225	76 TO 72 BTDC
0.200	62.5 TO 58.5
0.175	52 TO 48 BTDC
0.150	42 TO 38 BTDC
0.100	25.5 TO 21.5
0.050	8.5 TO 4.5 BTDC
0.020	8 TO 12 ATDC
0.006	47 TO 55 ATDC

28. Flywheel

- a. No modifications are allowed to the flywheel.
- b. The minimum weight of the flywheel, fins and attachment bolts is 4 pounds 1 ounce.
- c. Stock B&S part #555683 only. No machining, glass beading, sand blasting, painting or coating of flywheel is allowed.
- d. A flywheel fan, B&S part #692592/#555778, with broken fins must be replaced.
- e. Stock, unaltered B&S flywheel key with the B&S logo is required. Width of the key allowed is .1825" (4.6355mm)-.1875" (4.7625mm). No offset keyways allowed.

29. Ignition System

- a. **Unaltered B&S stock ignition** part #555681 is mandatory. Only "BLUE" ignition module allowed. Maximum RPM: 12,000.
- b. **Coil or its position**, other than air gap may not be altered in any way. Coil mounting bolts must be stock and cannot be altered in any way to advance or retard timing. Attachment bolts and/or bolt holes may not be altered.

- c. **Spark plug:** Only the Champion RC12YC is permitted. Spark plug must have the "Champion" logo as well as the RC12YC identification on the insulator. Sealing washer must be in place, unmodified as from the factory. Temperature thermocouple permitted as long as sealing washer and/or air guard are not modified.
- d. **Spark plug connector:** Only the OEM B&S part #555714 is permitted.
- e. **Magneto air gap** is non-tech (recommended clearance of .016" (0.41mm))
- f. **Static check for timing:**
 - Install a degree wheel using a positive stop method.
 - With the left edge of the first magnet aligned with the start of the lead leg of the ignition (refer to photo), the engine must not exceed 26 degrees with air gap set at .016" (0.41mm). Timing checked in the direction the engine operates.

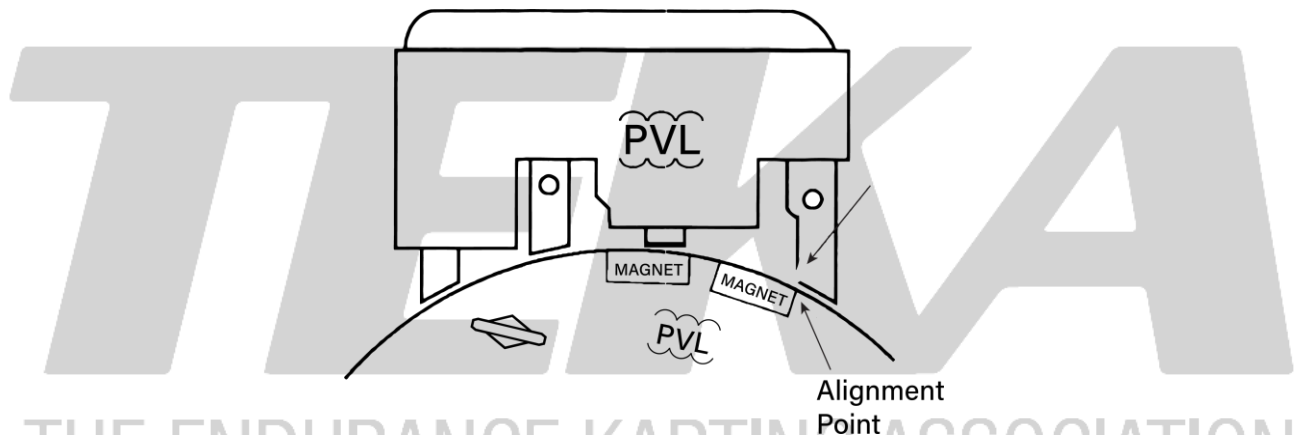

30. Crankcase

Crankcase and cover must be Briggs & Stratton stock, unaltered, "as cast in factory" condition. No alterations or subtractions of metal or any other substance to crankcase cover.

31. Clutch

- a. Only the Noram dry air cooled clutch GE20-219 is to be fitted.
- b. Clutches will be used to transmit the drive with a maximum engagement speed of not more than 2,500 rpm. All engagement shoes must be set to the number 1 (soft) position
- c. The Noram GE20 -219 clutch sprocket has 20 teeth.
- d. The final drive sprocket for use in TEKA is 71 teeth.
- e. The only permitted springs are the White "stock" springs supplied with the clutch

32. Starter

Recoil starter, B&S part #695287, must be retained, as produced and intact. Starter maybe rotated.

33. Exhaust System

- a. Complete exhaust manifold and muffler assembly must be as per TEKA Power Pipe specification and as supplied by TEKA.
- b. All mufflers must be tagged, stamped or engraved with TEKA permanent identification by TEKA
- c. TEKA mufflers also come with a bracket and mounting kit.
- d. Gasket and/or silicone are allowed to seal header to head. (One gasket maximum)
- e. Studs or bolts are permitted to fasten header to head. Bolts or nuts must be safety wired.
- f. Heli coiling of the exhaust is allowed.
- g. Any modification for or use of an O2, EGT, CO2 sensor is **prohibited**.

34. Non Tech Items

- a. Chain guards,
- b. engine mounts,
- c. rev counter or hour meter,
- d. inline fuel filter (no greater than 50ml capacity),
- e. catch can and brackets,
- f. fasteners, clips, ties, washers,
- g. throttle cable and housing, fuel line and pulse line

35. Technical Inspection Tools

A complete video of the Animal/206 inspection tools and process is available at www.BriggsRacing.com.

36. IMPORTANT online support resources

Please refer to www.Briggsracing.com for a host of resources. Due to the sealed nature of this engine we highly recommend reading and viewing important documents and videos to insure a great racing experience.









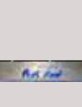
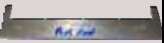

Located online:

- a. Engine tips and guide supplement – A must to print out and read BEFORE installing your engine!
- b. Carburetor tuning guide – Understand your carburetor to get the most out of your Animal/206.

**UNLESS THESE RULES STATE THAT YOU
CAN DO IT, YOU CANNOT DO IT.**

**EACH RACER IS SOLELY RESPONSIBLE TO MAINTAIN AND
CHECK ENGINE LEGALITY PER THIS PUBLISHED RULE SET**

37. TOOL REFERENCE

	Exhaust Valve Seat Diameter Max:0.850 Tool: A1
	Intake Valve Seat Diameter Max:0.972 Tool: A2
	Intake Port Pocket Bowl Gauge Max: 0.952
	Needle Jet Diameter Max:0.070 Tool: A4
	Push Rods Length Max: 5.658 Min: 5.638 Tool: A5
	Intake Inlet Diameter Max:0.918 Tool: A6
	Exhaust Outlet Diameter Max:0.980 Tool: A6
	Throttle Bore Diameter Max:0.874 Tool: A7
	Choke Bore Diameter Max: 1.149 Tool: A7
	Venturi Measurement Vertical Max:0.792 Tool: A8
	Horizontal Max: 0.615
	Air Pick Off Hole Tool: A9 Diameter .057" Go (Use .057" Class Z Go) .061" No-Go (Use .061" Class Z No-Go)
	Slide Cutaway Max: .075 Tool: A10 No go
	Intake Manifold Diameter Max: 0.905 Min: 0.885 Tool: A11
	Intake Manifold Length Max: 1.760 Min: 1.740 Tool: A12
	Rocker Arm Length Min: 2.820 Tool: A13

	Valve Spring Length Max:0.930 Tool: A15
	Rocker Ball Length Max:0.610 Min:0.590 Tool: A16
	Intake Valve Head Diameter Max:1.065 Min:1.055 Tool: A17
	Exhaust Valve Head Diameter Max:0.935 Min:0.945 Tool: A18
	Venturi Measurement Horizontal Min:0.602 Tool: A20
	Stroke Length Max:2.204 Tool: A21
	Valve Angle Angle Max: 45° Min: 45° Tool: A22
	Piston Pop Out Length Max: .0035 Tool: A25
	Intake Valve - Height from angle of valve face to top of the valve Length Min:0.057 Tool: A26
	Exhaust Valve - Height from angle of valve face to top of the valve Length Min:0.060 Tool: A27
	Width of Widest Part of Combustion Chamber Length Max:2.640 Tool: A30
	Slide Tool ASN Canada FIA National Class Structure Class Max. Slide Opening Junior 570" 'Yellow' Briggs & Stratton 206 Club Class Options, Class Max. Slide Opening Cadet .310" 'Black' Novice .342" 'Purple' Junior I .490" 'Green'
	Jetting Idle Pilot Jet – Stock, Unaltered .0130" No-Go (Use .0130" Class Z No-Go) Main Jet – open, no check
	Emulsion Tube Main nozzle – OEM stock unaltered hole size = .101, .104" Emulsion Tube - Small holes – .018 Go (Use .018" Class Z GO) .021" No-Go (Use .0215" Class Z No-Go) Big Holes - .026" Go (use .026" Class Z Go), .029" No-Go (Use .029" Class Z No-Go)

38. Parts diagrams

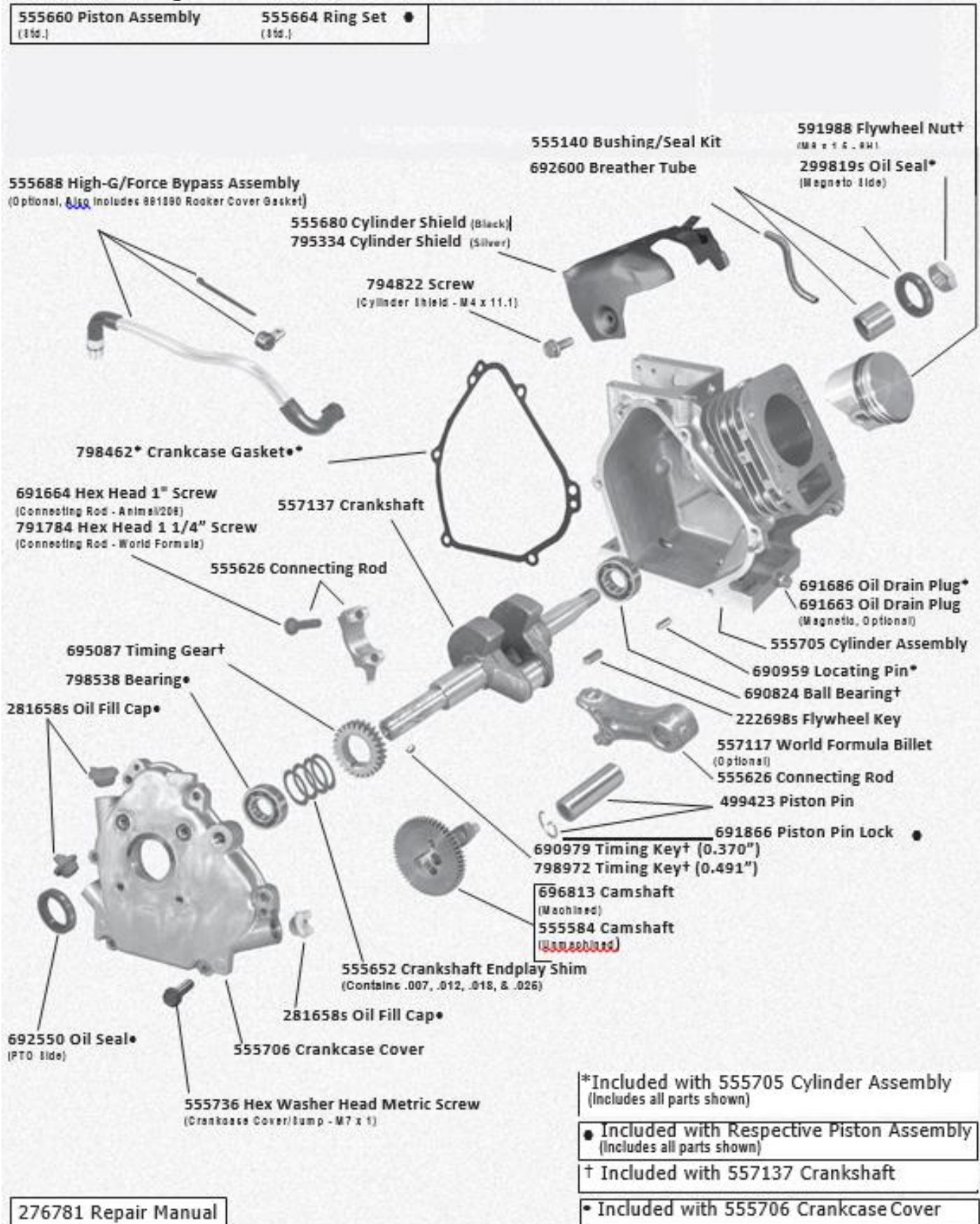

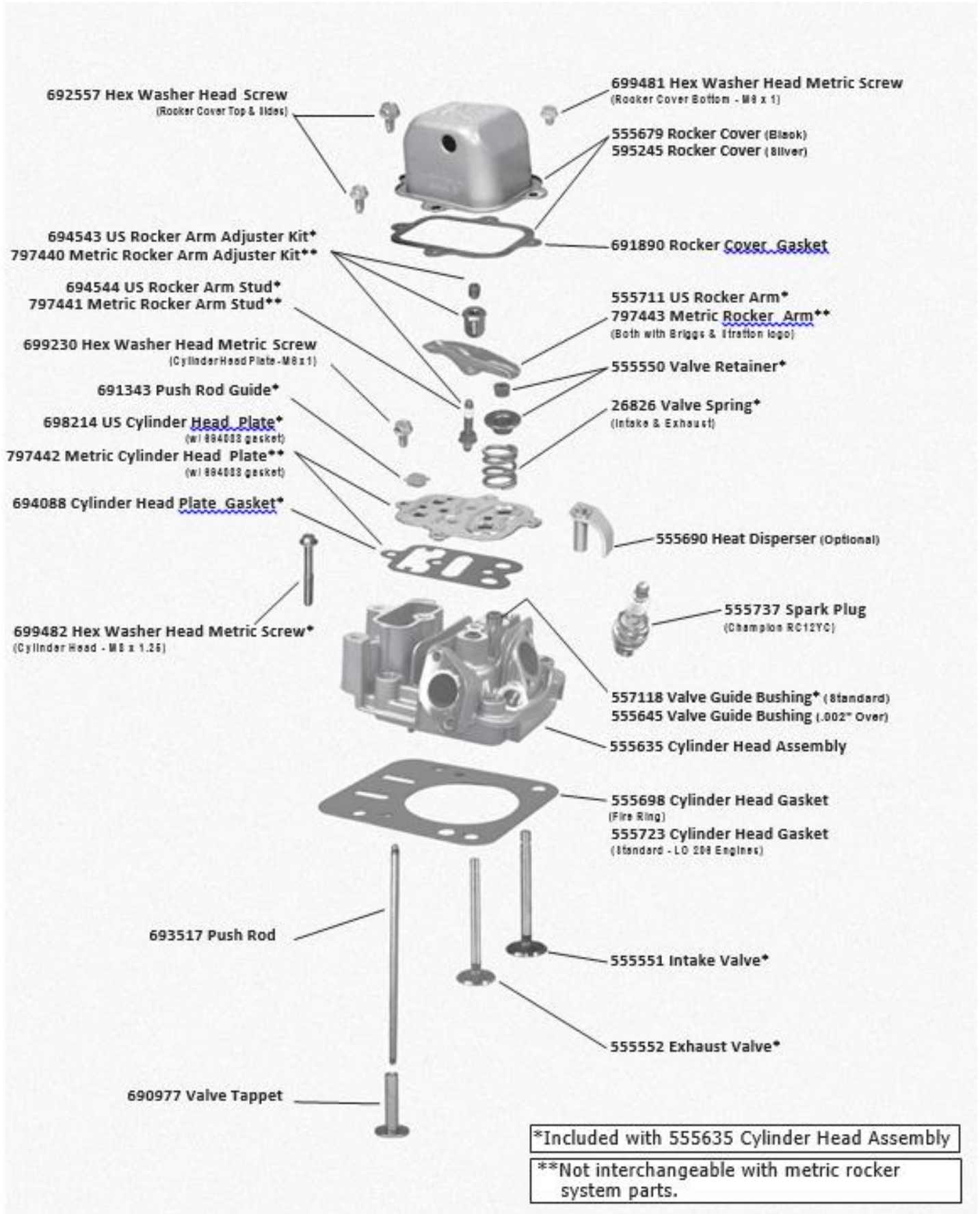

*Included with 555635 Cylinder Head Assembly

**Not interchangeable with metric rocker system parts.

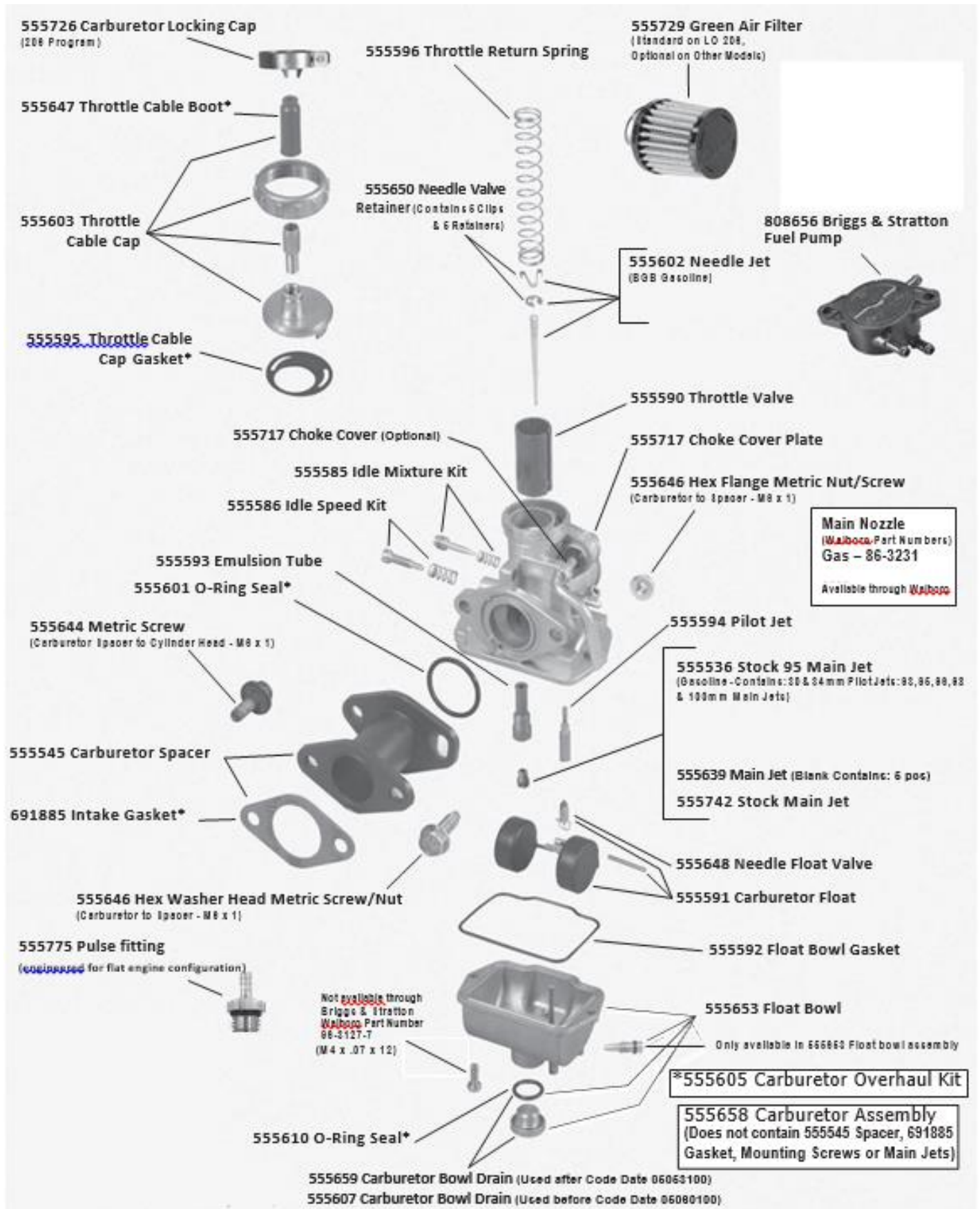

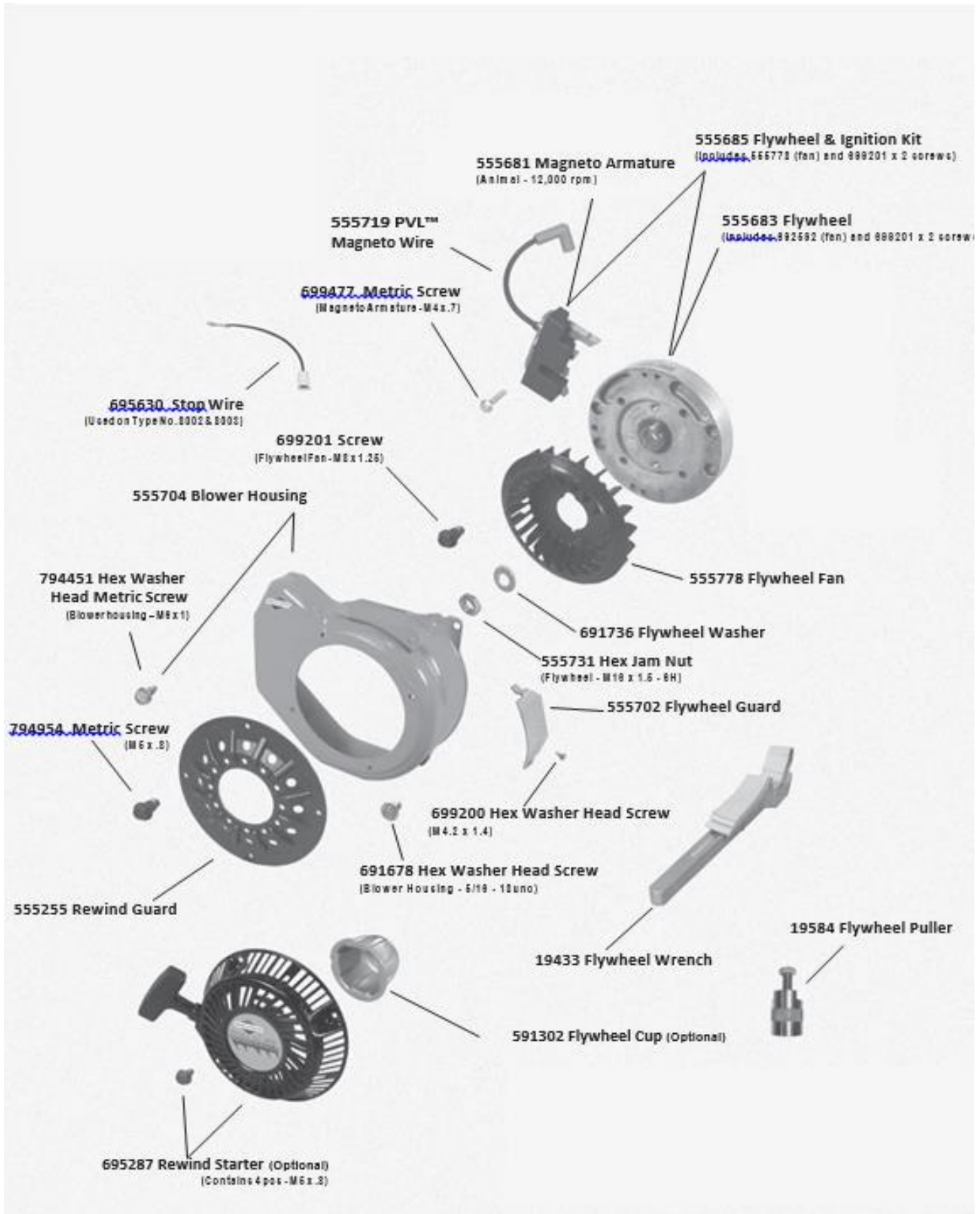



*Included with 555631 Engine Gasket Set

+ Included with 555636 Valve Gasket Set

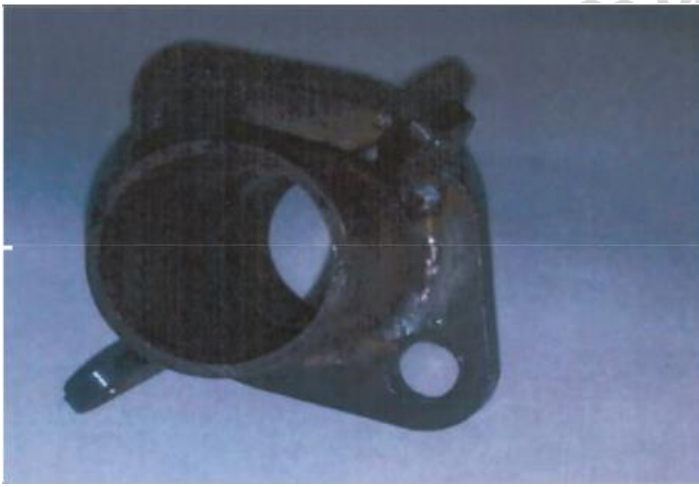
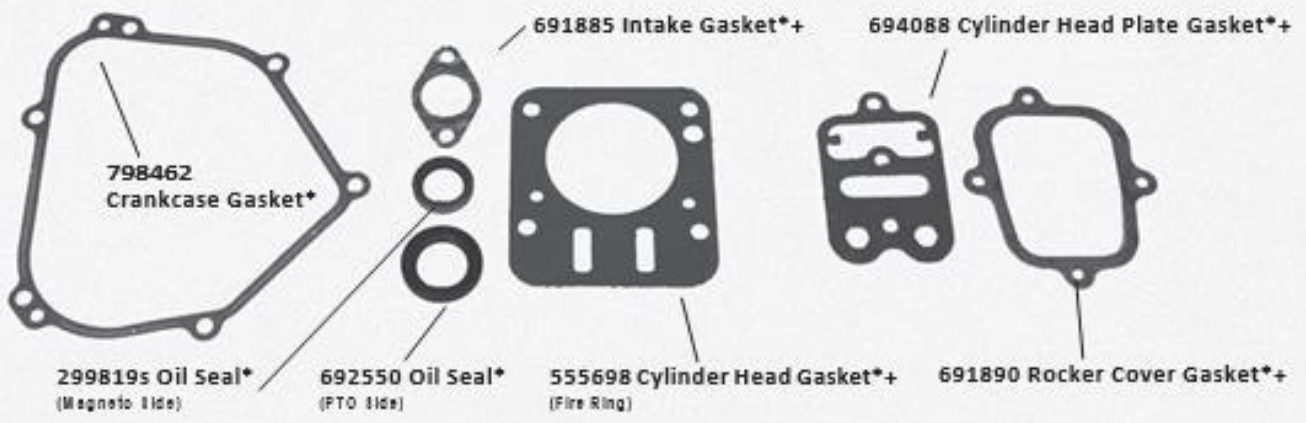



IEVA

THE ENDURANCE KARTING ASSOCIATION

20 YEARS

END OF DOCUMENT.